

NU-BL3010-10

300W (30V 10A) Brushless Motor Drive

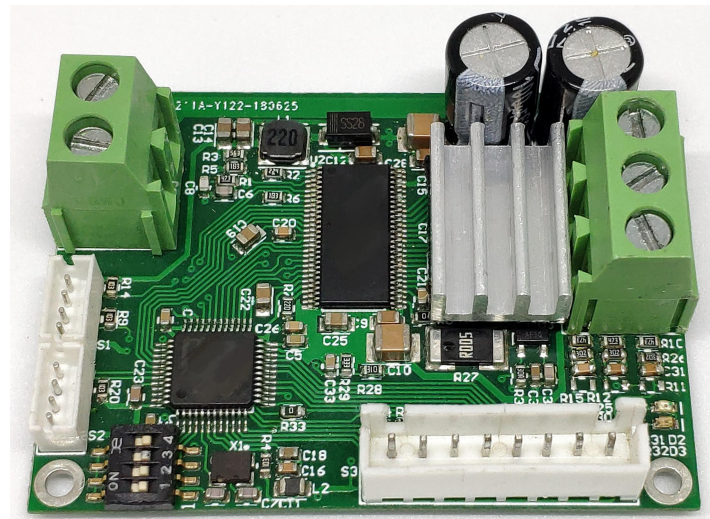

1. FEATURES

1. Brushless Motor sensorless drive.
2. PWM Frequency can be configured to accommodate different motors.
3. Multiple Speed input signals:
 - Analogue speed input
 - IIC BUS command speed input
 - Serial command speed input
4. Speed Ramp Implementation
For speed and direction change, to protect motor and drive.
5. Speed Feedback signal

2.CHARACTERISTICS

PARAMETER	DATA
Operating Voltage	12VDC~30VDC
Output Current (Continuous)	10A
Output Current (Maximum)	15A
Maximum Power	300W
Cooling method	Natural air cooling or forced air cooling
Environment	Avoid dust, oil mist and corrosive gases
Operating Temperature	0℃~+50℃
Storage Temperature	-20℃~+65℃
Dimensions	54mm*40mm*14.5mm
Weight	18g

3. INTERFACE

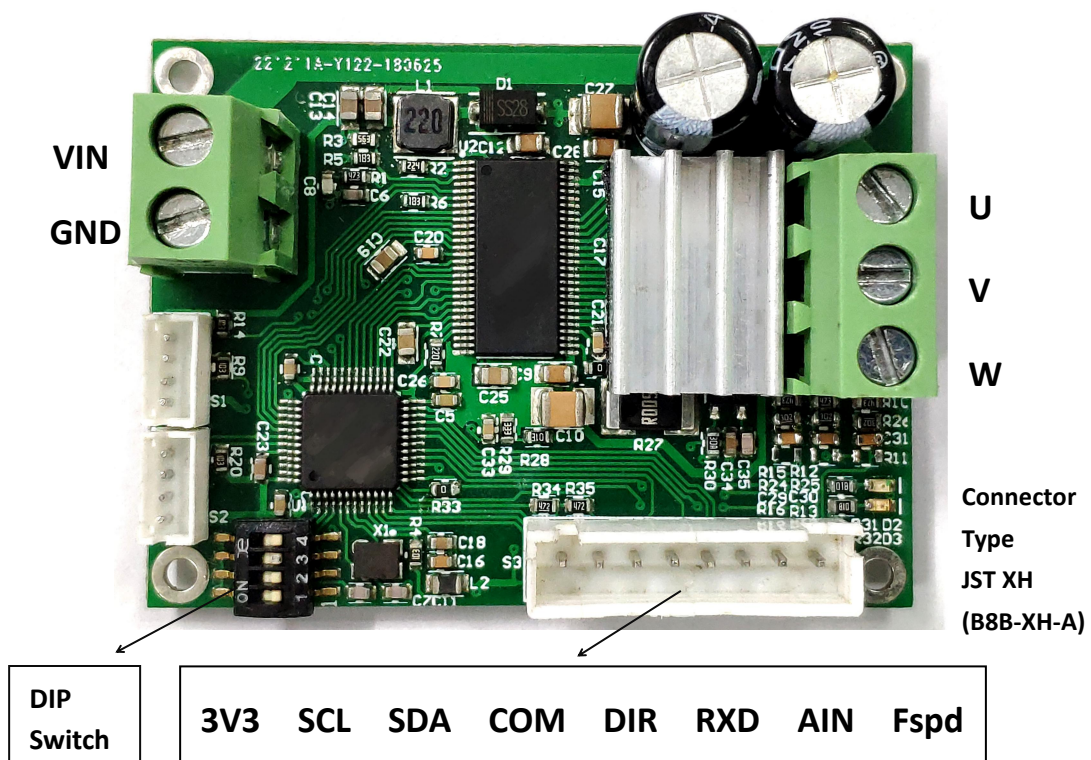

FUNCTION	SIGN	DESCRIPTION
Control	3V3	3.3VDC output
	SCL	IIC bus clock signal
	SDA	IIC bus data signal
	COM	Signal public
	DIR	Direction
	RXD	UART command input
	AIN	Analogue signal input
	Fspd	Speed feedback output
Motor and Power	U	Motor's U phase
	V	Motor's V phase
	W	Motor's W phase
	GND	Supply power input -
	VIN	Supply power input + (12VDC~30VDC)

Note: The drive is not polarity protected, please double-check the power connection before switch on the power input

4.FUNCTIONS

4.1 PWM Frequency Setting

The drive supports 5 PWM frequency settings. The DIP switch is used to select the different PWM frequency. The PWM frequency must be selected before power up.

PWM Frequency	SW1	SW2	SW3	SW4
20KHz	OFF	OFF	OFF	X
40KHz	ON	OFF	OFF	X
60KHz	OFF	ON	OFF	X
80KHz	ON	ON	OFF	X
100KHz	X	X	ON	X

Note: "X" switch can be on either 'ON' or 'OFF' position

4.2 Speed inputs

The drive supports 3 different speed input signals. External analogue inputs used input pin AIN. IIC BUS command inputs used input pin SCL and SDA. UART serial command inputs used input pin RXD. Analog/IIC/UART are all enabled at power up. If there is no digital signal (I2C/UART), analog input will be used. If there is digital signal (I2C/UART), analog input will be ignored.

Analog input:

The input range of external analogue input in 0.1 – 3.3VDC, It is recommended to use the 3.3V and Ground output from the drive; and use 10K Ω -50K Ω potentiometer.

IIC command input:

IIC Clock speed 400kHz

IIC address 0x29 (hex, 7bit) or 0x5A(hex, 8bit)

Speed command 8bit (0 slowest, 0x7F-- fastest)

Speed command "0x00" to enable the drive

Serial command input:

38400 baud rate

8bit data and 1 stop bit (8N1), no flow control

8bit speed command (0-slowest, 0x7F – fastest)

Send Sync byte '0xF5' before every speed command

Speed command 0x00 to enable the drive

4.3 Direction Input

Speed ramp control is used - direction change is allowed when motor is running at full speed. Internally pulled-up to 3,3V; connect to GND (COM) for rotating at opposite direction.

4.4 Speed feedback output

The speed feedback output signal outputs the speed signal at motor commutation frequency. The motor speed (RPM) can be calculated as –

$$\text{Motor Speed (RPM)} = F / \text{Pole_Pairs} * 60 \text{ (RPM)}$$

Where: F: Speed feedback frequency

Pole_Pairs: Motor pole pairs

For example:

One 4 pole motor, the output signal is 300Hz.

Motor speed = $300/2 \times 60 = 9000$ RPM.

5.DIMENSIONS

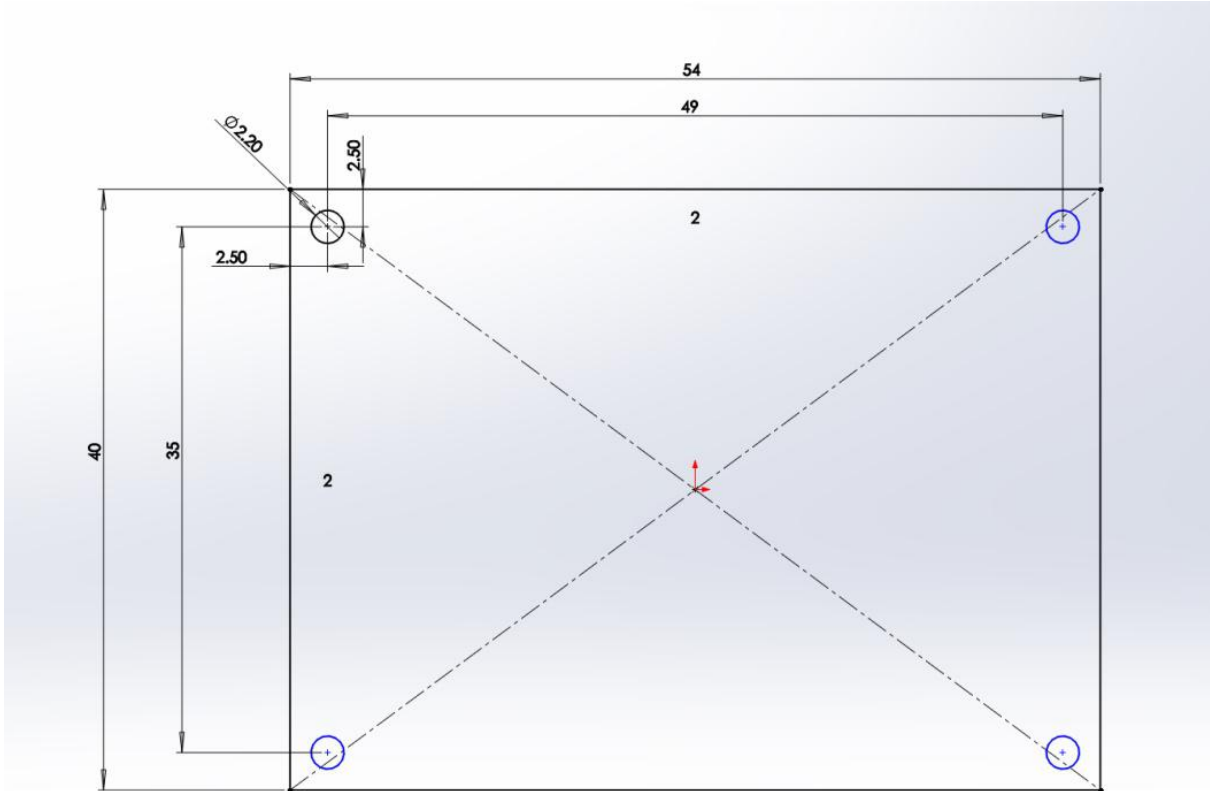

REVISION HISTORY		
Version	Date	Description
V1.0	2019/07/25	Initial Release
V1.1	2019/12/13	<ol style="list-style-type: none">1. changed the format2. Added weight information3. Add detailed instructions for speed feedback